

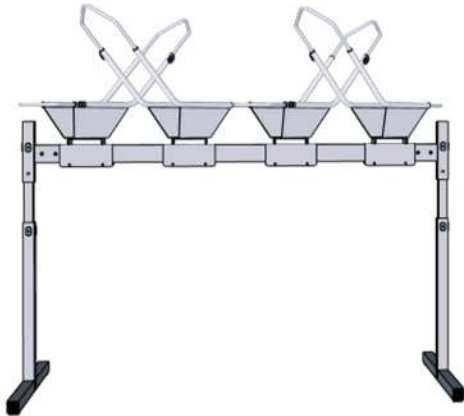

Designed & Made  
in the USA

# Fat Stand Up



## Parts



T-Base



Tray



Slide



Catch



Left End Post



Right End Post



Rail

**LOCATE ALL PARTS AND HARDWARE  
BEFORE BEGINNING RACK ASSEMBLY**

### Step 1:

Locate the Left End Post, one T-Base, and (2) 5/16" Knobs. Loosely thread the knobs into the sides of the T-Base.

Insert the Left End Post into the T-Base and secure it at an estimated starting height by tightening the knobs.

Repeat this step with the Right End Post and the remaining T-Base.



### Step 2:

Slide the ends of the Rail over the mounting ears on the End Posts.

Place a 5/16" Washer onto a 5/16" x 1/2" Bolt, insert through the holes in the Rail, and tighten securely.

### Step 3:

Locate a Tray and (2) Catches.

Slide the ends of the Catches into the tubes of the Tray.

Loosely secure both catches using 1/4" Thumbscrews.

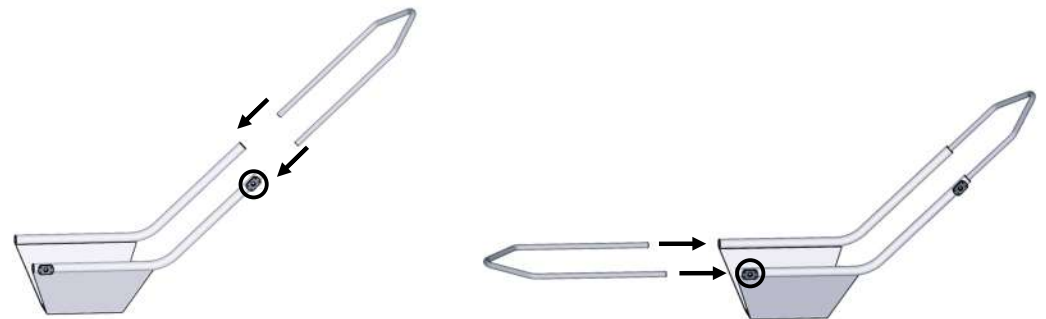



### Step 4:

Position the Tray Assembly onto the top of a Slide.

Secure the Tray with 1/4" x 3/4" Bolts and 1/4" Washers. Determine your desired angle and secure with 1/4" Washers and 1/4" Stop Nuts.

Repeat to complete the remaining Assemblies.

### Step 5:

Place the Slide Assemblies onto the rail.

After the assemblies are spaced as desired, secure by inserting 1/4" x 1-3/4" Bolts through the front of the holes on the Slide and securing from the back with 1/4" Stop Nuts.

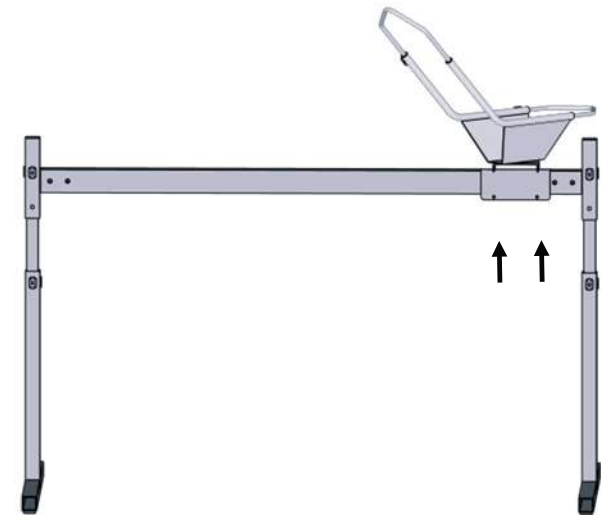

### Recommended Cradle Spacing

Rail Length	Cradles	Slide to Slide (your choice)	Inches from End
47"	2		2-3/4"
47"	3	11.5"	2-3/4"
47"	4	5.75"	2-3/4"

## Step 6:

As a finishing detail, insert 1-1/4" Plugs into the exposed tubes.

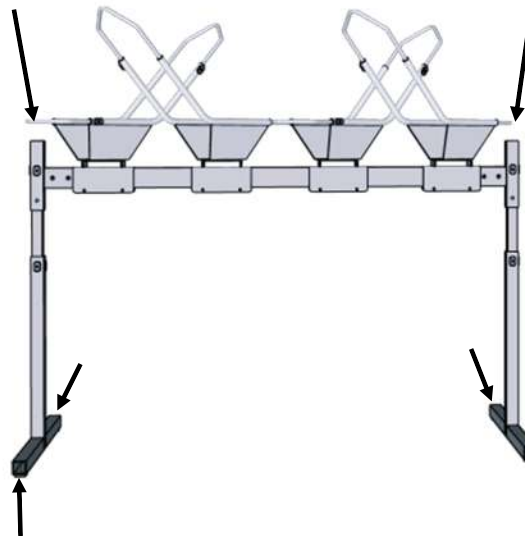

*Your rack is  
complete!*



**Loading Bikes:**  
Center the front wheel over  
the Tray. Adjust the Catches.