

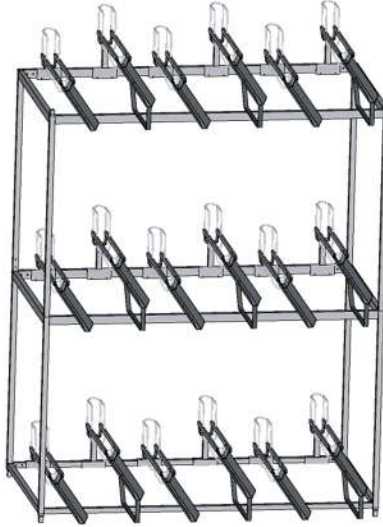

Designed & Made  
in the  
USA

# WALL DOUBLE DECKER 3-Tier with Trays on All Tiers



## HARDWARE

- 1/4" x 3/4" Bolts
- 1/4" x 1-3/4" Bolts
- 1/4" Washers
- 1/4" Stopnuts
- Thread Rolling Bolts
- 5/16" x 1/2" Bolts
- 5/16" X 3/4" Bolts
- 5/16" x 1" Bolts
- 5/16" Washers
- 1/2" x 1" Black Plugs
- 1" Black Plugs
- 1-1/4" Black Plugs
- 1/4" x 3/8" Set Screws

## TOOLS NEEDED:

- \*socket wrench with 7/16" and 1/2" sockets
- \*7/16" wrench
- \*1/2" wrench
- \*tape measure

**LOCATE ALL PARTS  
AND HARDWARE  
BEFORE  
BEGINNING RACK  
ASSEMBLY**

## PARTS

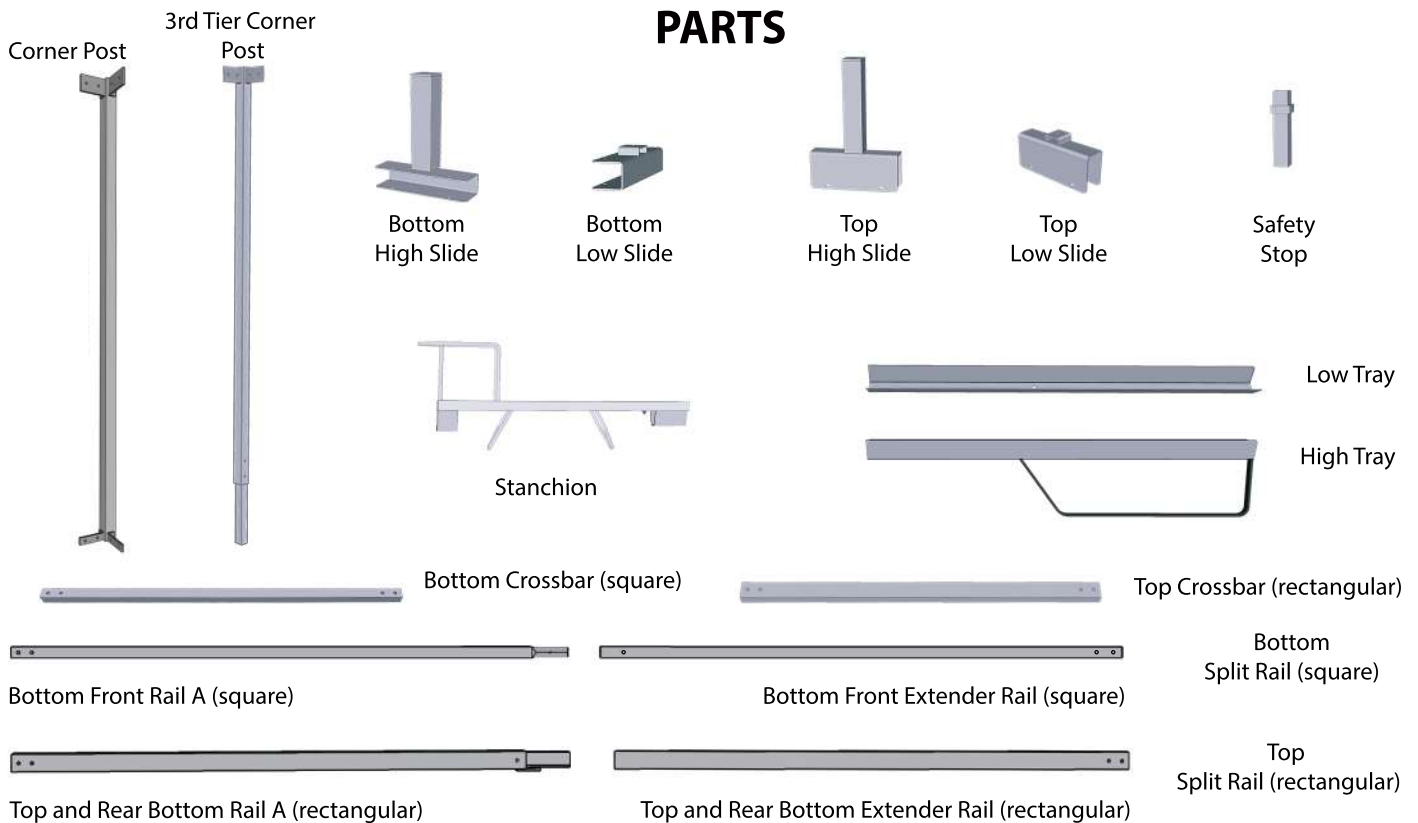

### 3-Tier Wall Double Decker Rail Assembly

Your Wall Double Decker includes the following rails: (4) Top Rails – Rectangular, and (2) Bottom Rails – Square

#### Step 1 – Identify Rail Components

Each rail is shipped in two pieces:

*Rail A – with end that inserts into the extender*



Bottom Rail A (square)



Top Rail A (rectangular)

*Rail Extender*



Bottom Extender Rail (square)



Top Extender Rail (rectangular)

#### Step 2 – Assemble Each Rail

Insert Rail A into the Rail Extender until it stops and the connection is flush.

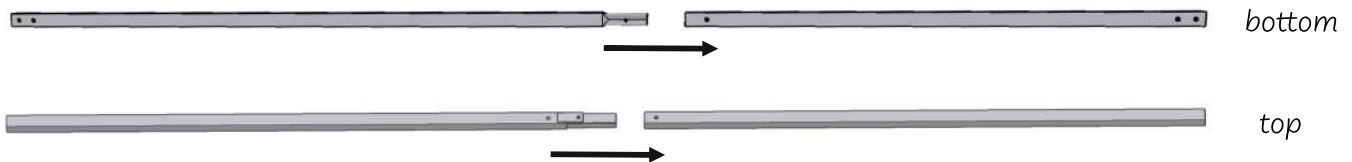

#### Step 3 – Secure Top Rails

For the four Top Rails, secure using: a 5/16" × 1" Bolt and 5/16" Washer.

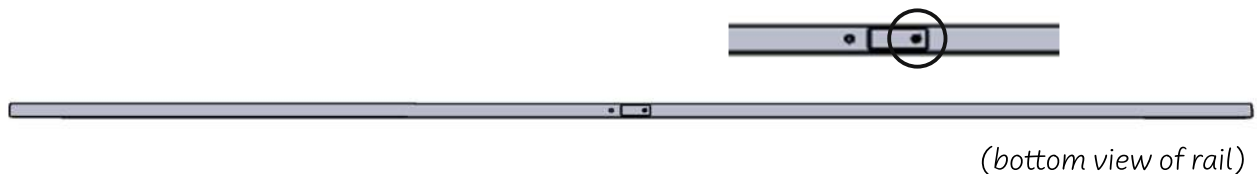

#### Step 4 – Secure Bottom Rails

For the two Bottom Rails, secure using a Thread Rolling Bolt.



*Apply steady downward pressure while turning, as the bolt will widen the hole. (Use a rubber mallet to align holes if needed.)*

## TRAY ASSEMBLY (HIGH and LOW TRAYS)

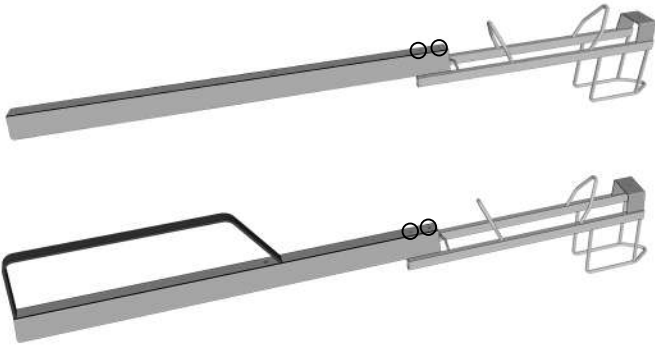

Locate the Stanchions and Trays. Flip a Stanchion and Tray upside down. Align the 2 holes in the Stanchion with the 2 holes in the Tray. The Tray should be on the outside of the Stanchion, as shown.

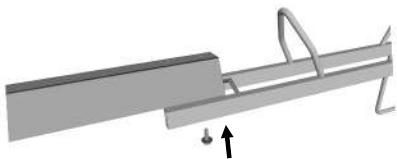

Place a 1/4" washer over a 1/4" x 3/4" Bolt. Insert the assembly through one of the holes. Finger tighten with a 1/4" Washer and 1/4" Stopnut.



Repeat in the open hole, as shown. Tighten using (2) 7/16" Wrenches.

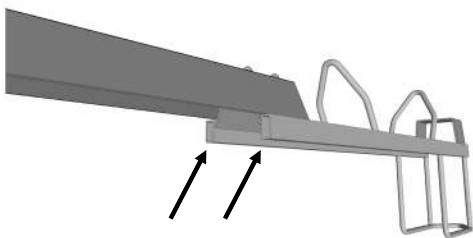

Insert (2) 1/2" x 1" Plugs into the open holes in the front of the Stanchion, as shown.

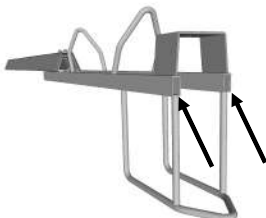

Insert (2) 1/2" x 1" Plugs into the back of the Stanchion, as shown.

Your tray is now complete!

For ease of assembly, finger-tighten all bolts until Step 4 is complete. This will allow for easier adjustments and alignment throughout the process. Once step 5 is complete, securely tighten all bolts to finish 2-Tier Frame Assembly.

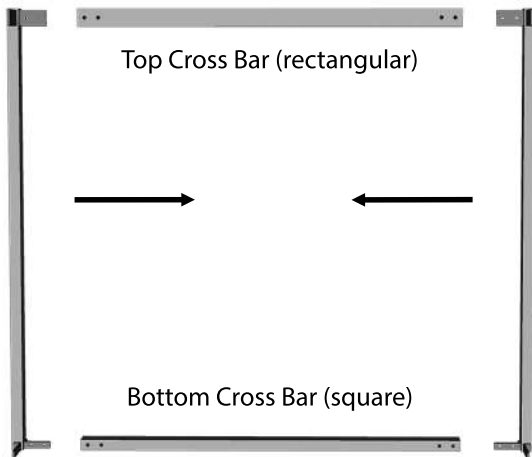

### Step 1:

Create the End Assemblies: Locate (2) Corner Posts, (1) Bottom Crossbar, and (1) Top Crossbar.

Create an End Assembly by laying parts on a flat surface, inserting the ears on the Corner Posts into the Crossbars as shown. Secure by hand tightening 5/16" x 1/2" Bolts and 5/16" Washers.

Repeat once more with the remaining Corner Posts and Crossbars to create another End Assembly.

### Step 2:

Locate the (2) Bottom Rails [square]. While holding one End Assembly upright with the small ears on the bottom, slide the ends of the rails over the ears as shown.

Secure by hand tightening 5/16" x 1/2" Bolts and 5/16" Washers.

Repeat on the opposite side with the remaining End Assembly.

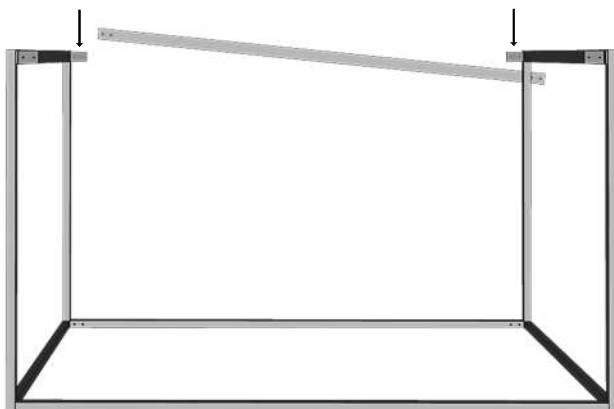
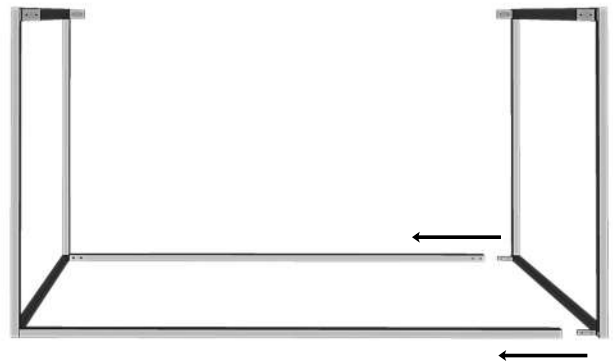

### Step 3:

Locate a Top Rail. Slide one end over one of the ears on a Corner Post. Then place the other end of the Rail over the corresponding ear at the other side of the rack, as shown. NOTE: It may take a little force to get onto both ears.

Secure by hand-tightening 5/16" x 1/2" Bolts and 5/16" Washers.

### Step 4:

Repeat Step 3 with the front Top Rail. Once again, this may require a little force.

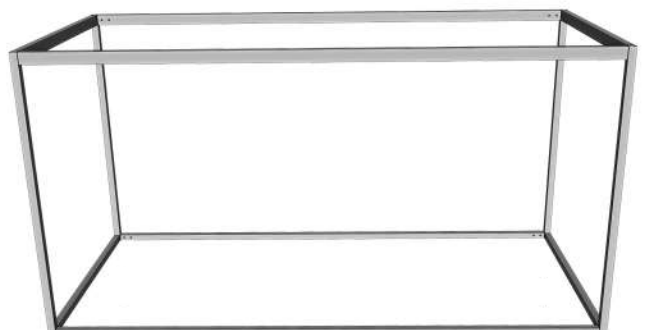

## Step 5:

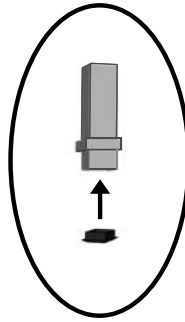
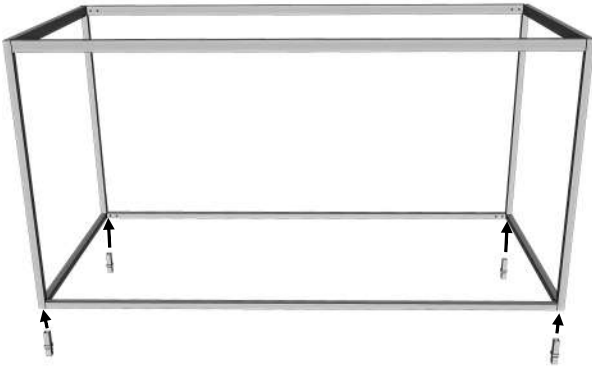

Locate the (6) Safety Stops.  
Insert 1" Black Plugs into the  
Safety Stops as shown.

Lift each corner of the structure  
and slide the long side of a Safety  
Stop into the bottom of the (4) Corner  
Posts (Plug facing down), as shown.

Set the remaining (2) Safety Stops  
to the side for use in Step 9.

**Go back through the entire  
frame and tighten all bolts.**

**Your 2-Tier Frame is complete!**

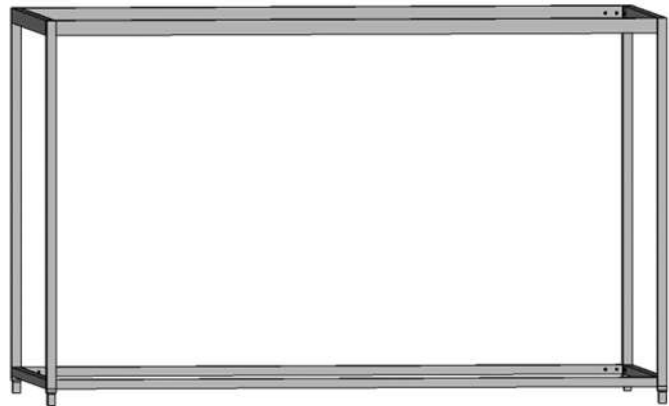

For ease of assembly, finger-tighten all bolts until third tier frame is complete. This will allow for easier adjustments and alignment throughout the process. Once step 7 is complete, securely tighten all bolts to finish frame assembly.

## Step 6:

Insert the 3rd Tier Corner Posts into the tops  
of the lower Corner Posts.

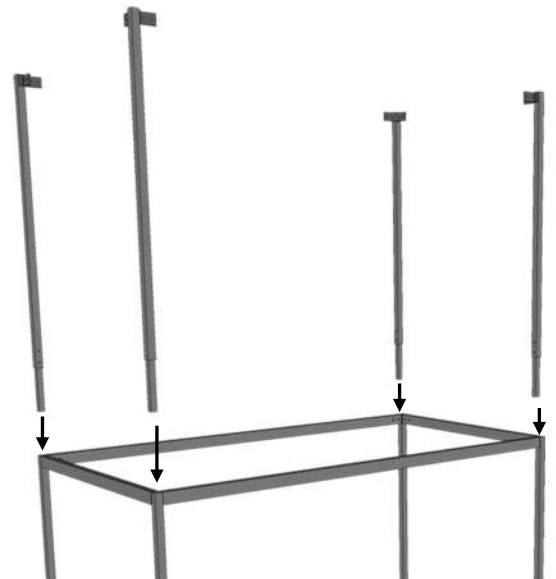

## Step 7:

Insert the remaining Top Cross Bars into the ears of the 3rd Tier Corner Posts and secure by finger tightening 5/16" x 1/2" Bolts with 5/16" Washers.

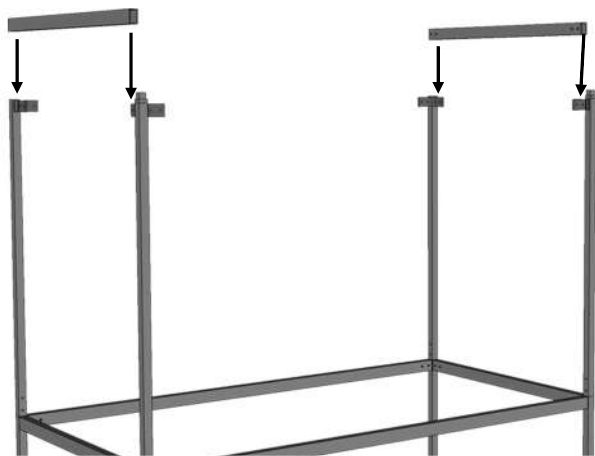

## Step 8

Locate a Top Rail. Slide one end over one of the ears on a 3rd Tier Corner Post. Then place the other end of the Rail over the corresponding ear at the other side of the rack  
NOTE: It may take a little force to get onto both ears.

Secure by hand-tightening 5/16" x 1/2" Bolts and 5/16" Washers.

Repeat with the final Top Rail.



## Step 9:

Locate the (2) remaining Safety Stops.

Insert the long end of each Safety Stop (Plug on top) into each of the front 3rd Tier Corner Posts.

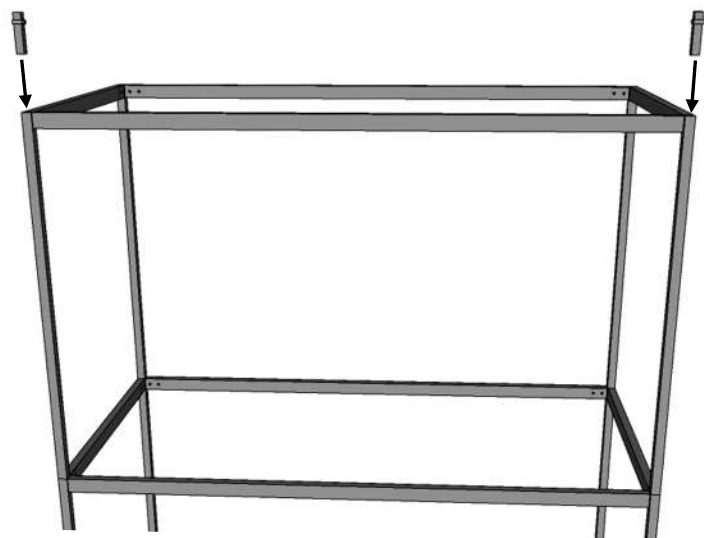

## Step 10:

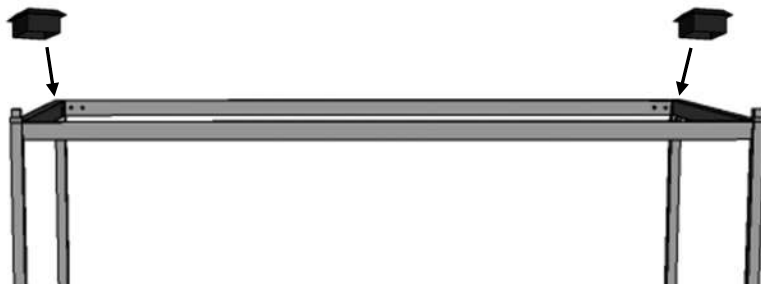

Locate (2) 1-1/4" Black Plugs and insert them into the two Rear 3rd Tier Corner Posts.

**Go back through the 3rd Tier Frame and fully secure all bolts.**

**YOUR 3-TIER FRAME IS NOW COMPLETE!**

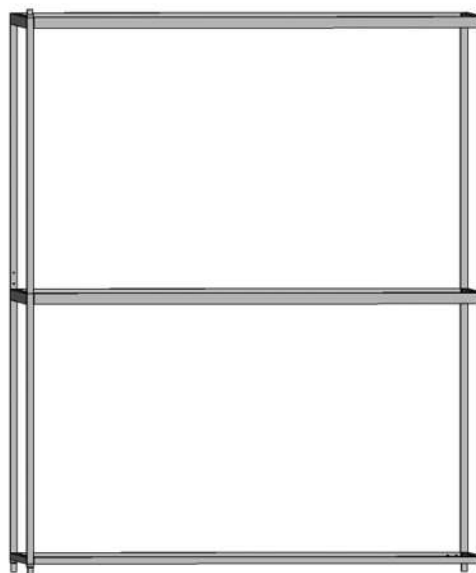

## Step 11: Slide Attachment

Begin on the bottom tier by locating the Bottom Low and High Slides. Position each slide at the front of the rear square rail, then fit the C-channel around the rail and push it straight back until it fully seats, with the open side facing the back of the rack, as shown.

### Slide Placement Tip:

When placing the slides, we generally recommend leaving approximately 3.5" to 4" of space at each end of the rail. The slides themselves can be spaced approximately 7" to 8" apart (end to end) depending on your setup. The slides can be adjusted to fit your specific needs.

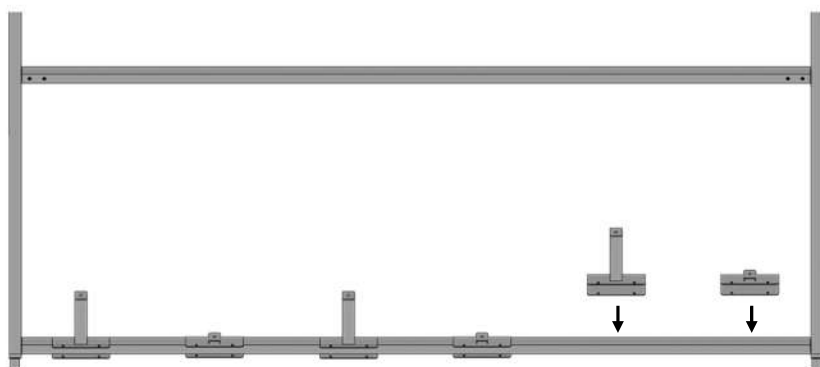

*Back View of Bottom Tier Rear Rail*

## Step 11 --Slide Attachment-- Continued:

Secure the bottom tier slides by placing 1/4" x 1-3/4" Bolts through the holes on the back of the slide and securing with 1/4" Stop Nuts.

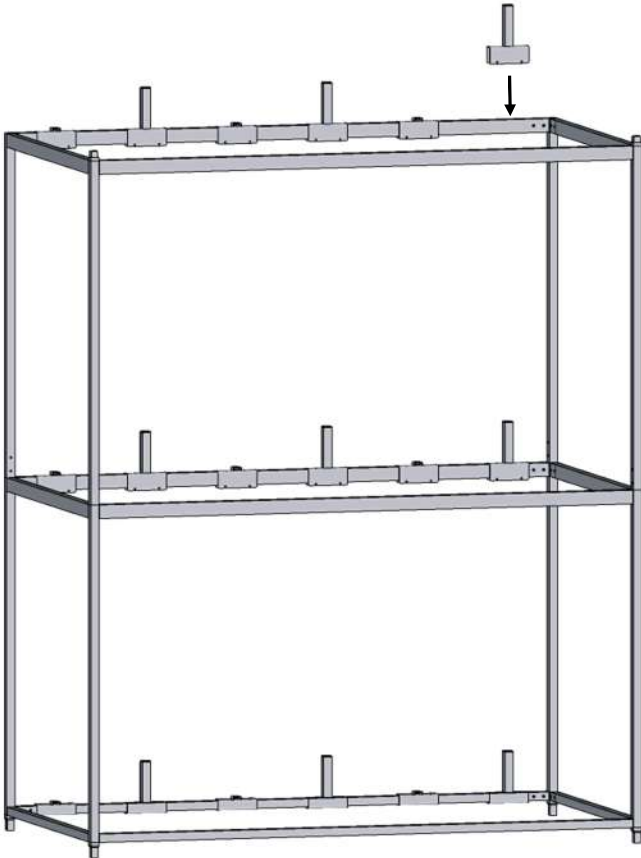

Next, locate the Upper High and Low Slides.

Stagger the 2nd and 3rd tier High and Low Slides to match the spacing on the bottom tier.

Secure the 2nd and 3rd tier slides by inserting a 1/4" x 1-3/4" Bolt through the front of each hole and securing in the back with a 1/4" Stop Nut.

## Step 12: Tray Attachement

Locate the pre-assembled High and Low Trays.

Beginning on the Bottom Tier:

Secure each Low Tray to its corresponding Low Slide by inserting a 5/16" x 1/2" Bolt with a 5/16" Washer through the rear hole of the tray assembly and into the top of the Slide.

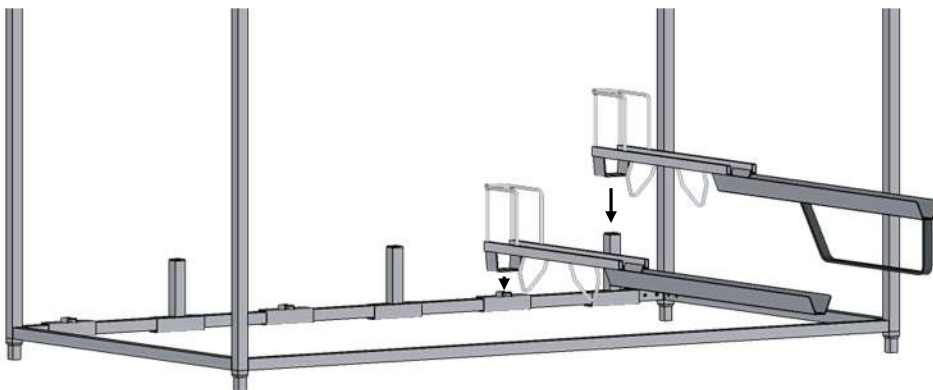

Secure each High Tray to its corresponding High Slide by inserting a 5/16" x 3/4" Bolt with a 5/16" Washer through the rear hold of the tray assembly and into the top of the Slide.

## Step 12 --Tray Attachment-- Continued:

Repeat on the 2nd and 3rd Tiers.

Secure each Low Tray to its corresponding Low Slide by inserting a 5/16" x 1/2" Bolt with a 5/16" Washer through the rear hole of the tray assembly and into the top of the Slide.

Secure each High Tray to its corresponding High Slide by inserting a 5/16" x 3/4" Bolt with a 5/16" Washer through the rear hole of the tray assembly and into the top of the Slide.

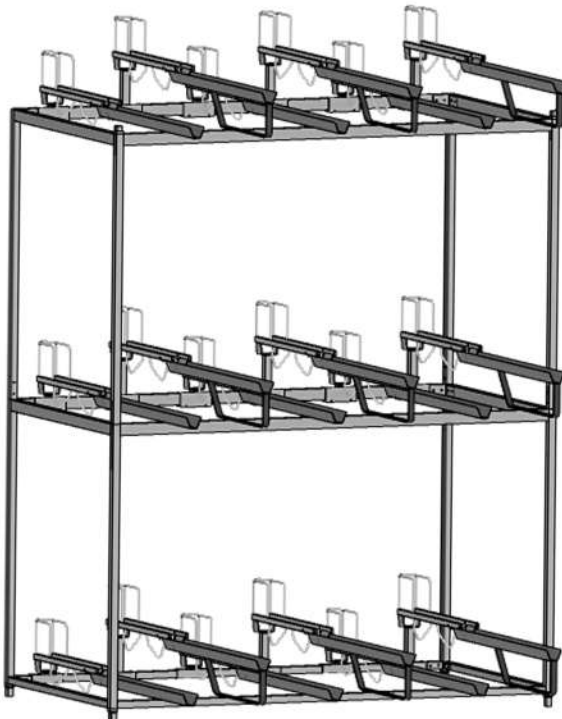
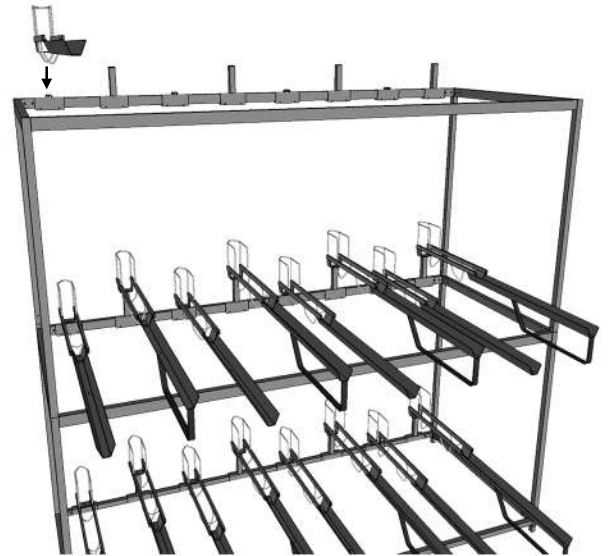

YOUR RACK  
IS  
COMPLETE!

### BEFORE LOADING BIKES ON TRAYS:

*It is recommended that the rear derailleur is set on the middle cog and the front derailleur is set on the largest chain ring to prevent chain or derailleur damage.*