

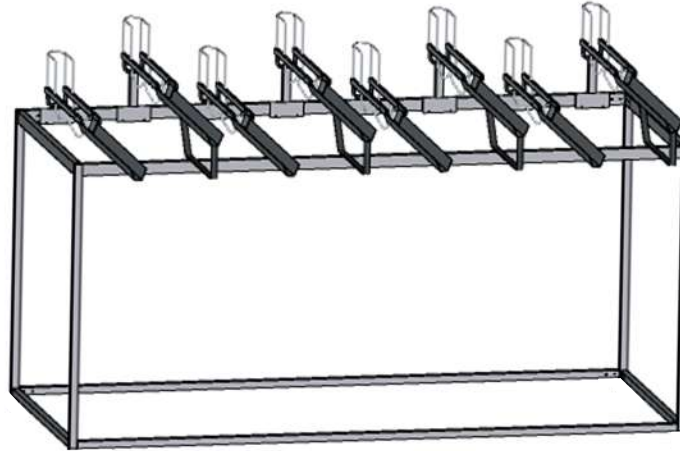

WALL DOUBLE DECKER Tray Top Only

Designed & Made
in the
USA



HARDWARE

- 1/4" x 3/4" Bolts
- 1/4" x 1-3/4" Bolts
- 1/4" Washers
- 1/4" Stopnuts
- Thread Rolling Bolts
- 5/16" x 1/2" Bolts
- 5/16" X 3/4" Bolts
- 5/16" x 1" Bolts
- 5/16" Washers
- 1/2" x 1" Black Plugs
- 1" Black Plugs
- 1-1/4" Black Plugs

TOOLS NEEDED:

- *socket wrench with 7/16" and 1/2" sockets
- *7/16" wrench
- *1/2" wrench
- *tape measure

**LOCATE ALL PARTS
AND HARDWARE
BEFORE
BEGINNING RACK
ASSEMBLY**

PARTS

54" Corner Post

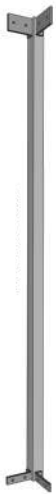

Stanchion



Low Tray



High Tray

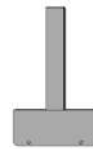

Top High Slide



Top Low Slide



Safety Stop

Bottom Crossbar (square)

Top Crossbar (rectangular)

Bottom Front Rail A (square)

Bottom Front Extender Rail (square)

Bottom Split Rail (square)

Top and Rear Bottom Rail A (rectangular)

Top and Rear Bottom Extender Rail (rectangular)

Top Split Rail (rectangular)

Wall Double Decker Rail Assembly

Your Wall Double Decker includes the following rails: (2) Top Rails – Rectangular, and (2) Bottom Rails – Square

Step 1 – Identify Rail Components

Each rail is shipped in two pieces:

Rail A – with end that inserts into the extender



Bottom Rail A (square)



Top Rail A (rectangular)

Rail Extender



Bottom Extender Rail (square)



Top Extender Rail (rectangular)

Step 2 – Assemble Each Rail

Insert Rail A into the Rail Extender until it stops and the connection is flush.

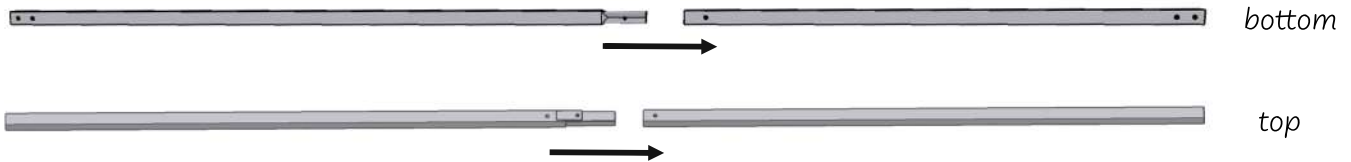

Step 3 – Secure Top Rails

For the two Top Rails, secure using: a 5/16" × 1" Bolt and 5/16" Washer.

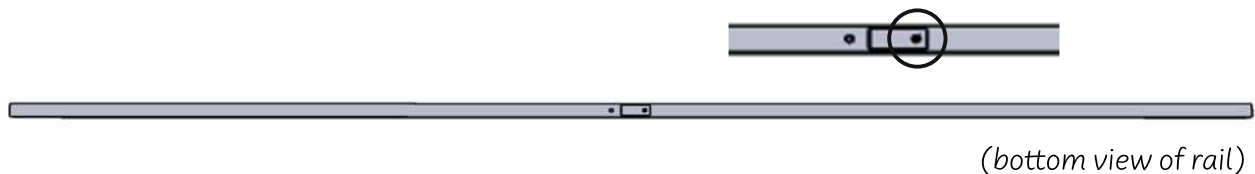

Step 4 – Secure Bottom Rails

For the two Bottom Rails, secure using a Thread Rolling Bolt.



Apply steady downward pressure while turning, as the bolt will widen the hole. (Use a rubber mallet to align holes if needed.)

TRAY ASSEMBLY (HIGH and LOW TRAYS)

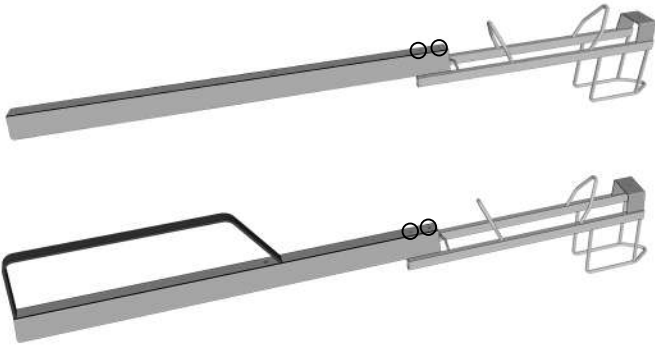

Locate the Stanchions and Trays. Flip a Stanchion and Tray upside down. Align the 2 holes in the Stanchion with the 2 holes in the Tray. The Tray should be on the outside of the Stanchion, as shown.

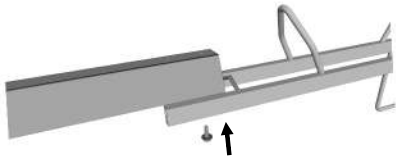

Place a 1/4" washer over a 1/4" x 3/4" Bolt. Insert the assembly through one of the holes. Finger tighten with a 1/4" Washer and 1/4" Stopnut.



Repeat in the open hole, as shown. Tighten using (2) 7/16" Wrenches.

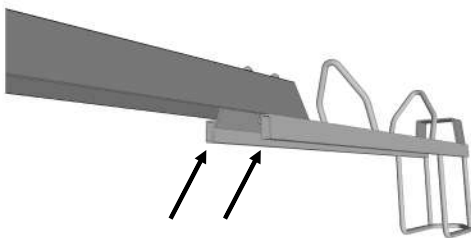

Insert (2) 1/2" x 1" Plugs into the open holes in the front of the Stanchion, as shown.

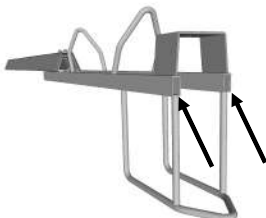

Insert (2) 1/2" x 1" Plugs into the back of the Stanchion, as shown.

Your tray is now complete!

For ease of assembly, finger-tighten all bolts until Step 4 is complete. This will allow for easier adjustments and alignment throughout the process. Once step 4 is complete, securely tighten all bolts to finish frame assembly.

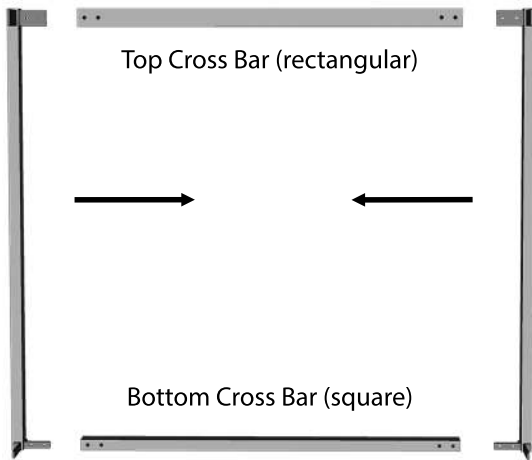

Step 1:

Create the End Assemblies.: Locate (2) Corner Posts, (1) Bottom Crossbar, and (1) Top Crossbar.

Create an End Assembly by laying parts on a flat surface, inserting the ears on the Corner Posts into the Crossbars as shown. Secure by hand tightening 5/16" x 1/2" Bolts and 5/16" Washers.

Repeat once more with the remaining Corner Posts and Crossbars to create another End Assembly.

Step 2:

Locate the (2) Bottom Rails [square]. While holding one End Assembly upright with the small ears on the bottom, slide the ends of the rails over the ears as shown.

Secure by hand tightening 5/16" x 1/2" Bolts and 5/16" Washers.

Repeat on the opposite side with the remaining End Assembly.

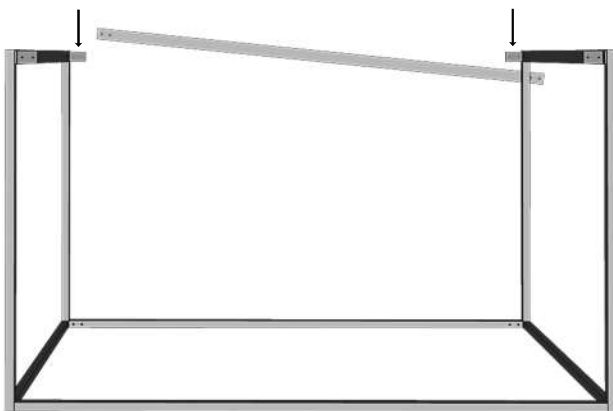
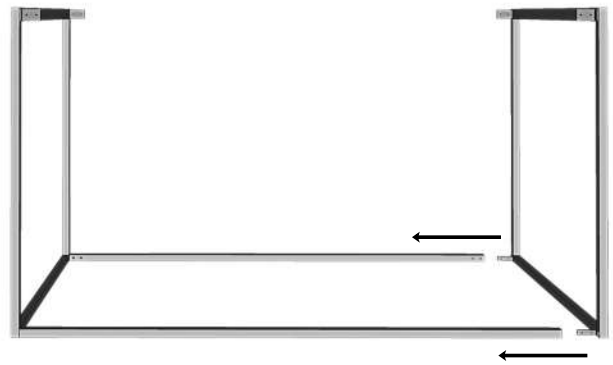

Step 3:

Locate a Top Rail. Slide one end over one of the ears on a Corner Post. Then place the other end of the Rail over the corresponding ear at the other side of the rack, as shown. NOTE: It may take a little force to get onto both ears.

Secure by hand-tightening 5/16" x 1/2" Bolts and 5/16" Washers.

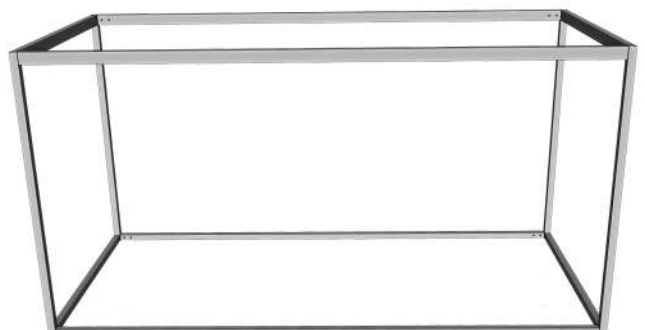

Step 4:

Repeat Step 3 with the remaining Top Rail. Once again, this may require a little force. Now your structure is complete.

Go back through the entire frame and tighten all bolts.

Step 5:

Find the High and Low Slides and position them along the Top Rear Rail. Begin at one end, alternating High and Low Slides as illustrated. Secure each slide with 1/4" x 1-3/4" Bolts and 1/4" Stopnuts.

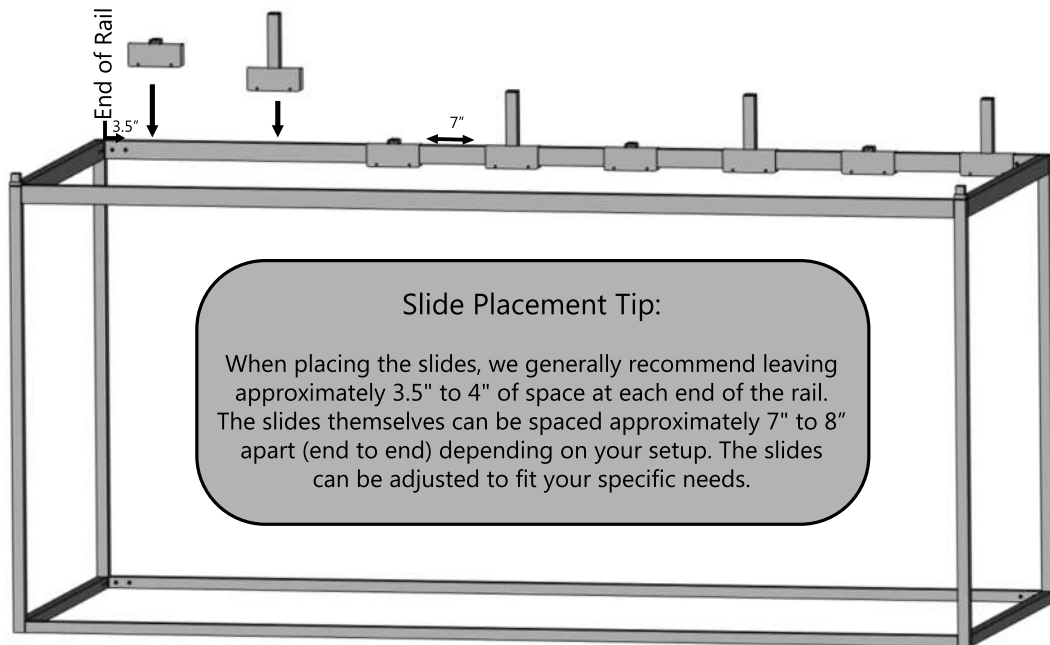

Step 6:

Attach each Tray Assembly to its matching Slide:
Low Trays to Low Slides, and High Trays to High Slides.

Insert the bolt through the **back hole** of the tray assembly and into the hole on top of the slide.

Secure Low Trays using 5/16" x 1/2" Bolts and 5/16" Washers.

Secure High Trays using 5/16" x 3/4" Bolts and 5/16" Washers.

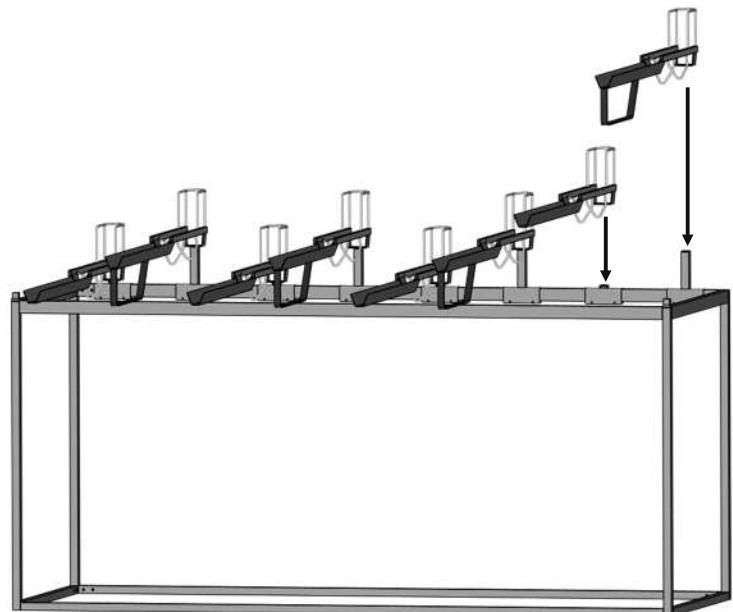

Step 7:

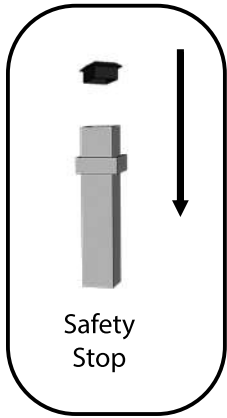

Locate the two Safety Stops. Push a 1" Black Plug into the top, as shown. Insert each Safety Stop into one of the Front Corner Posts. Next insert 1-1/4" Black Plugs into the tops of the Rear Connector Posts.

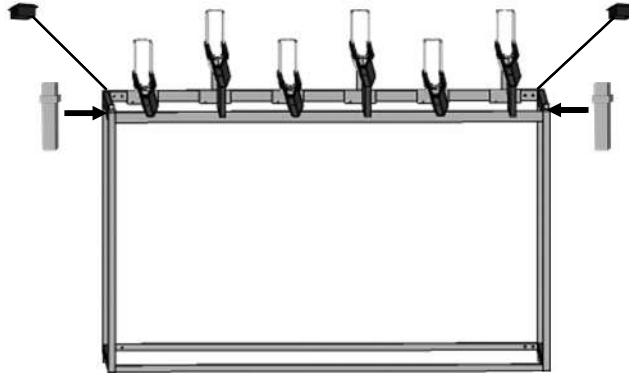

YOUR RACK IS
NOW COMPLETE!

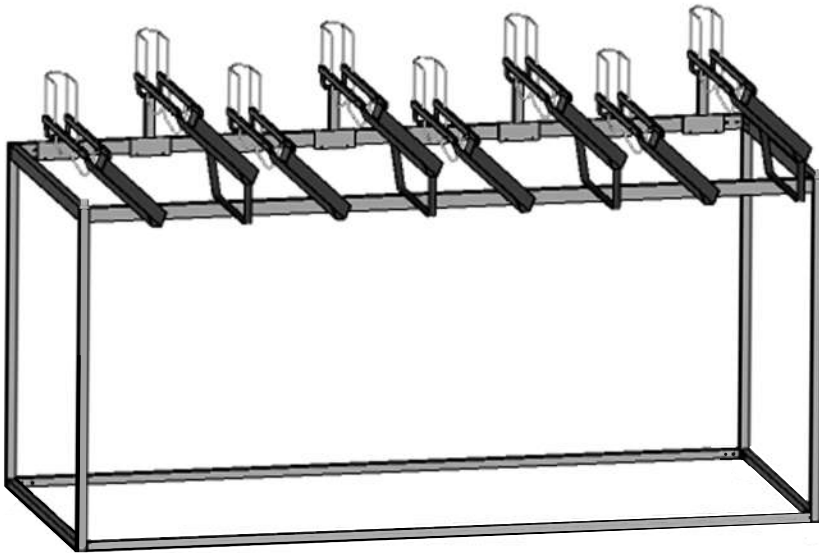

Before loading bikes: If your bike has a rear derailleur it is recommended that the rear derailleur is set to the lowest gear (the largest rear chain ring) to prevent chain or derailleur damage