



Recumbent Trike 2-Tier



1. Front Tray



2. 5 Way Base



3. Vert Post



4. 12" Leg



5. 24" XBar



6. Main Support



7. Front Tee



8. Main Slide



9. Upper Tray

HARDWARE

5/16" X 1/2" BOLTS
1" BLACK PLUGS
1-1/4" BLACK PLUGS

ASSEMBLY INSTRUCTIONS

STEP ONE:

Locate the (2) Bases. Place them on the floor as shown. Place the X-Bar in between the shorter legs with one of the threaded holes facing up and the other toward the back of the rack. Secure with 5/16" x 1/2" Bolts on each side.

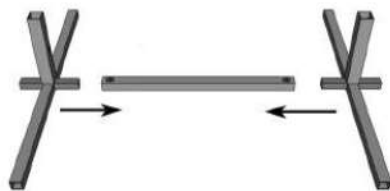

STEP TWO:

Locate the (2) Legs and slide them on as shown. One of the threaded holes should face up and the other should face the back of the rack. Secure using 5/16" x 1/2" Bolts.

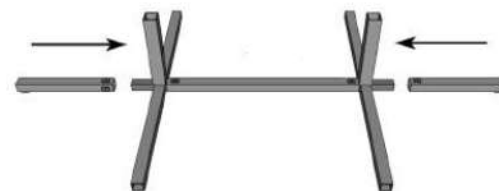

STEP THREE:

Locate the (2) Vertical Posts. Slide either end into the top of each 5-Way Base, as shown. Make sure to slide the posts down as far as possible, making sure the post tops are even. Secure with 5/16" x 1/2" Bolts.



STEP FOUR:

Locate the Main Support. Slide the open vertical tubes over the two Vertical Posts. Make sure the pitch of the center tube is sloping down back to front.



Set the desired height of the top tier and secure using 5/16" x 1/2" Bolts.



STEP FIVE:

Insert the Main Slide into the center tube of the Main Support. The threaded holes should face toward the front of the rack. Secure with 5/16" x 1/2" Bolts.



STEP SIX:

Slide the Upper Tray on the Main Slide. The horizontal tube should be toward the back of the rack.

Secure loosely using 5/16" x 1/2" Bolts. This part can be adjusted later but start with it a few inches from the end, as shown.



ASSEMBLY INSTRUCTIONS



STEP SEVEN:
Locate the Front Tee and slide it in the bottom of the Main Slide, as shown.

This part can be adjusted later to fit the trike. Loosely tighten in place using 5/16" x 1/2" Bolts.

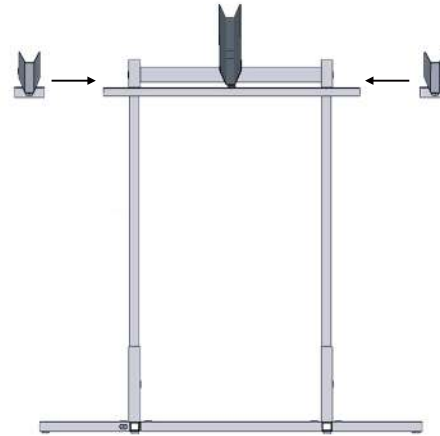

STEP EIGHT:
Locate the two Front Trays. Slide them onto the ends of the Front Tee, as shown.

Tighten loosely in desired placement using 5/16" x 1/2" Bolts.

This spacing can be adjusted later.



STEP NINE:
Set the adjustable parts to your desired width and length, tightening all the bolts as your rack is set into place.

Insert the appropriately sized plugs into all exposed ends of tube to give the rack a finished appearance.

YOUR RACK IS COMPLETE!